

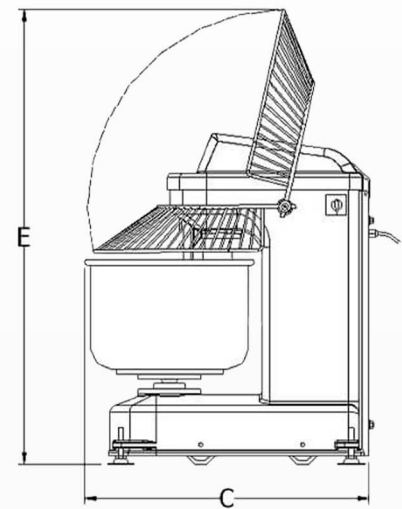

DYNASTY

3Kg Spiral Mixer

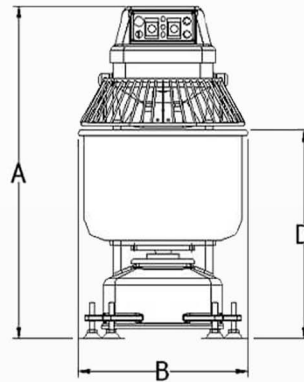

HL-17003K

Product Character

Feature:

- The 3 Kgs flour capacity spiral mixer is with a 2 HP motor.
- Both the bowl and agitator can rotate and the agitator is with 2-speed option.
- Stainless steel safety guard is standard. As the lift of safety guard, the mixer's limit-switch is automatically shut off to protect operator.

Specifications

Model No.	Capacity		Dimensions (mm)					Net Weight	Motors
	Flour	Bowl	A	B	C	D	E		
HL-11012	3 Kg	15 L	565	346	586	342	770	55 kg	2 Hp

Note: The water content needs to be above 60%, and the flour below 60% needs to be havled).

- Any three phase is available, please specify voltage when ordering.
- Due to product improvement, specifications are subject to change without notice
- 1 Quart = 0.95 Liter