



DYNASTY

7 Quart Gear Driven Desktop mixer



HL-11007A



HL-11007

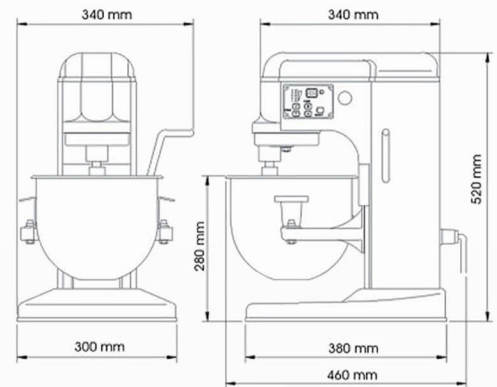

Product Character

- Professional and counter-top style.
- Motor offer enough power to mixing stiffer doughs and larger batches.
- All metal and Die-cast aluminum body.
- Transmission is made of harden alloy steel gears.
- All shafts are mounted in ball bearing
- Automatic electronic 5-speed control and digital timer
- Planetary-mixing action ensures perfect results.
- Simple hand lift for tool change and bowl removal.
- Safety guard is standard for model HL-11007A and provides you with automatic shut-off when guard is opened at any speed.

Standard Accessories

- 7 Qt. Stainless Steel Bowl
- Dough hook
- Flat Beater
- Wire Whip

Specifications

Model No.	Bowl Capacity	Motor	Agitator Speeds (RPM)	Digital Control Panel	Safety Guard	N.W.
HL-11007	7 Quart (6.65Liter)	650W (110V)	193-495 RPM	Std.	Std.	18 KG
HL-11007A				Std.		

- A - Safety Guard
- 1 Quart = 0.95 Liter

* Standard Voltages: 100 -120 Volts/single phase, 208-240 Volts/single phase.

The Bakery Equipment Specialist