



DYNASTY

12 Quart Gear Driven Desktop mixer



GM12A



GM12

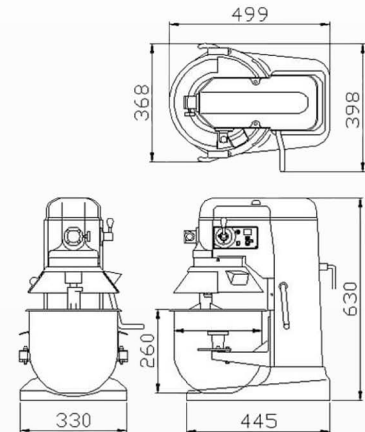

Product Character

- This Mixer is an advanced design, high reliable professional food processing tool.
- This Mixer is equipped with powerful 1/2HP motor and strong gear driven design.
- The gears are made of heat-treated alloy steel and a hardness steel worm wheel.
- There are 3 speeds and 3 types of accessories, which can be selected to obtain the best using results.

Standard Accessories

- Spiral Dough Arm
- Flat Beater
- Wire Whip
- 12 Quart Bowl

Optional Accessories

- 7 Quart bowl
- 7 Quart Spiral Dough Arm
- 7 Quart P-Type Beater
- 7 Quart Wire Whip
- Safety Guard
- #12 Hub
- Meat Grinder Attachments
- C-Type Hook
- P-Type Beater

Specifications

Model No.	Bowl Capacity	Motor	Agitator Speeds (RPM)	Digital Control Panel	Safety Guard	N.W.
GM12	12 Quart (11.4 Liter)	1/2 HP 0.375 kW	60HZ: 146 / 262 / 516	Std.	Std.	35 KG 77 Lbs
GM12A			50HZ: 122 / 219 / 430	Std.		

- H - Hub Attachment
- A - Safety Guard
- 1 Quart = 0.95 Liter

* Available Voltages: 100 -120 Volts/single phase, 208-240 Volts/single phase.

* Due to product improvement, specifications are subject to change without notice.

The Bakery Equipment Specialist