

SINMAG

SPIRAL MIXER - FIXED BOWL SERIES

FEATURES:

- * Digital control panel
- * Solid construction.
- * SM2-25, SM2-50 single-motor driven
- * From SM2-50T, two motors.
- * Short mixing time with excellent kneading result
- * Switch for manual or automatic function.
- * Withdust cover
- * Mounted on castors, easily movable.
- * Stainless steel hook and bowl.
- * ABS plastic cover or safety grids cover for choice. (SM2-25, ABS safety cover only)

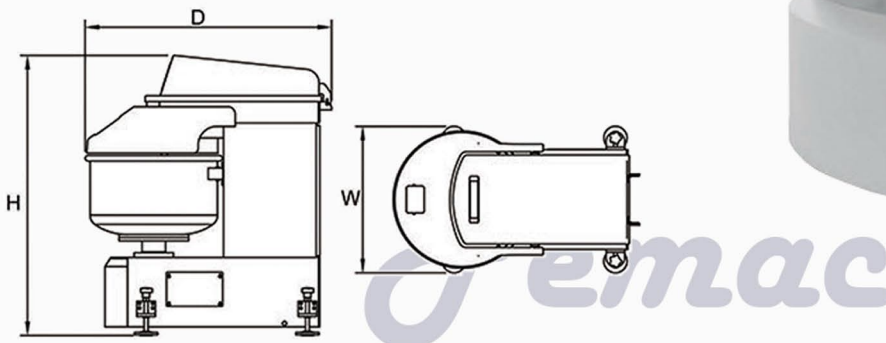

Model	SM2-25	SM2-50	SM2-50T	SM2-60T	SM2-80T	SM2-120T	SM2-200T
Flour capacity	2 - 15 Kg	4 - 30 Kg	4 - 30 Kg	4 - 40 Kg	4 - 50 Kg	6 - 75 Kg	10 - 120 Kg
Dough capacity	3 - 25 Kg	6 - 50 Kg	6 - 50 Kg	6 - 60 Kg	6 - 80 Kg	9 - 120 Kg	15 - 200 Kg
Spiral Power	2,2 kW	3 kW	3 kW	4,12 kW	4,5 kW	6 kW	12 kW
Bowl Power	/	/	0,75 kW	0,75 kW	0,75 kW	0,55 kW	1,5 kW
Spiral speed 1st speed	140 rpm	135 rpm	135 rpm	135 rpm	125 rpm	110 rpm	98 rpm
Spiral speed 2nd speed	280 rpm	270 rpm	270 rpm	270 rpm	250 rpm	220 v	196 v
Bowl speed 1st speed	12.8 rpm	12.8 rpm	17.8 rpm	17.8 rpm	17.2 rpm	13 v	11 rpm
Bowl speed 2nd speed	25.5 rpm	25.5 rpm	17.8 rpm	/	17.2 rpm	13 rpm	11 rpm
Weight	155 kg	285 kg	285 kg	325 kg	425 kg	640 kg	1050 kg
Outside Dimension W*D*H	590 X 880 X 1100 mm	640 X 1080 X 1120 mm	640 X 1080 X 1220 mm	660 X 1000 X 1300 mm	765 X 1280 X 1310 mm	830 X 1470 X 1460 mm	980 X 1710 X 1580 mm
Voltage	3 PH X 230/400V 50 HZ						