

Z.MATIK DOUGH LOVERS

Dough sheeter (Four standing)



SHE 60120

The SHE model sheeter is compact and with a design that allows the operator to work comfortably. The mechanics keep some key points, but they are also renewed, allowing the customer less maintenance and greater resistance.

The goal is to make this range even more solid and intuitive, thus facilitating the operator especially in routine cleaning. The dough sheeter is perfect for multiple applications: from pastry shops to hotels, catering, etc. Existing options have been made even more advanced

SHE 500/600 SFOGLIATRICI CON BASAMENTO | FLOOR STANDING SHEETERS

TIPO	SHE50075	SHE50100	SHE50120	SHE60100	SHE60120	SHE60140*	SHE6014DT	SHE6016DT
A (mm)	900	900	900	900	900	900	900	900
B (mm)	1215	1215	1215	1215	1215	1215	1215	1215
C (mm)	2290	2555	3020	2555	3020	3410	3410	3810
D (mm)	1820	2090	2550	2090	2550	2940	2940	3345
E (mm)	1030	1030	1030	1130	1130	1130	1130	1130
F (mm)	820	820	820	920	920	920	920	920
G (mm)	1165	1430	1490	1430	1490	1700	2560	
H (mm)	1630	1700	1965	1700	1965	2130	2130	
Apertura cilindri Cylinders opening (mm)	50	50	50	50	50	50	50	50
Diametro cilindri Cylinders diameter (mm)	80	80	80	80	80	80	80	80
Larghezza nastri Conveyor belts width (mm)	500	500	500	600	600	600	600	600
Potenza Power (kw)	0,55	0,55	0,55	0,75	0,75	0,75	0,75	0,75
Potenza Power (hp)	0,75	0,75	0,75	1	1	1	1	1
Peso Weight (kg)	205	210	215	265	275	280	310	315

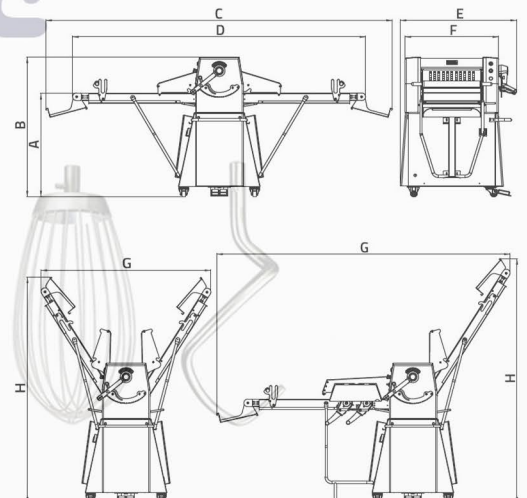

Per il modello SHE6014DT (cioè con piani di lunghezza 1400 mm e dispositivo di taglio) è possibile mettere solamente il piano destro in posizione di riposo (come riportato in figura). Per il modello SHE6016DT non è consentita posizione di riposo.

The model SHE6014DT (tables length 1400mm each + cutting device) can be put in rest position only with the right side as showed in the picture. The model SHE6016DT cannot be put the rest position.