



MKF 511TS

ELECTRIC COMBI OVEN WITH TOUCH SCREEN 5 TRAYS 1/1 GN



Who said that you always have to give something up in small kitchens?

With MKF 511 TS you can have everything you've always wanted in the kitchen, and maybe a lot more: 500 storable recipes, the possibility of choosing between traditional cooking and direct steam and an elegant and easy-to-use display.

MILLENNIAL's innovation at the service of professionals who does not compromise, ever.

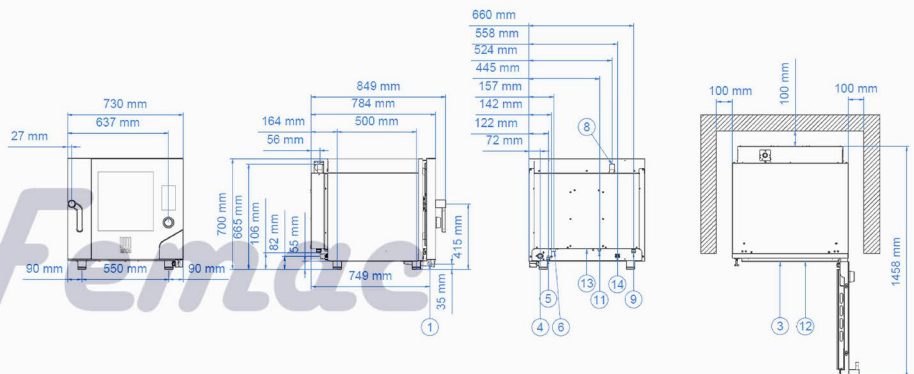

Capacity	5
Distance between rack rails (mm)	68
Oven dimension(WxDxH) (mm)	730 x 849 x 700
Weight (kg)	78,4
Power supply (kW)	7,8
Voltage (V)	AC 380/400 3N
Frequency (Hz)	50/60
Temperature (°C)	30 ÷ 270