

 中井機械工業株式会社

 **HOT MIX**

Easy-to-use, stable dough making for everyone

Touch Panel Memory

The touch panel memory can save up to 20 menu items. It perfectly and automatically reproduces your usual operation.

Wireless Temperature Sensor

The wireless temperature sensor detects the temperature from the pan bottom on the induction heating (IH). This sensor is ideal for a variety of processes, ranging from the stage of dissolving ingredients in the hot water to the stages in making cream puff dough and jam.

Unique Twin Whippers

These uniquely developed, heterogeneous whippers achieve fine and uniform foaming



THM - 100L

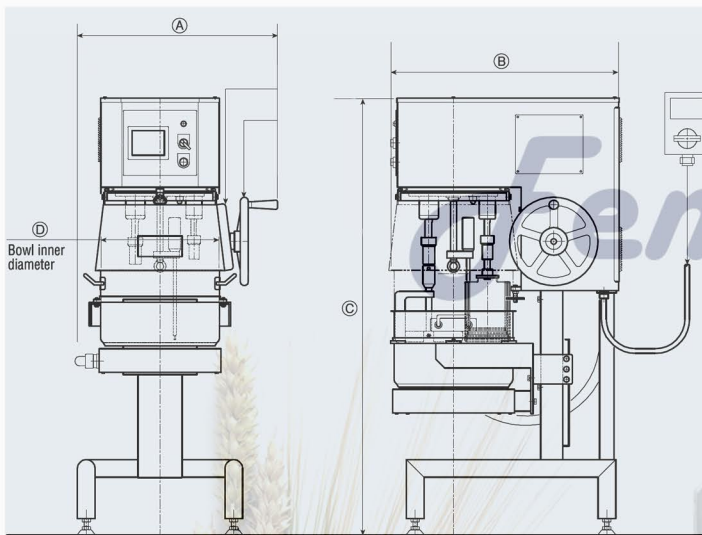

Model	A Opening	B Depth	C Height	D Pot Inner Diameter	Weight	Pot Capacity	Power Capacity	Mixing motor
THM-100-L	1070 Including operation panel	1190	1930	600	700 kg	100 L	3-phase, 200 V, 13 kW	2.2 kW (3 HP)