



VM07(A)

- Professional and counter-top style
- 650-watts motor offer enough power to mixing stiffer doughs and larger batches
- All metal and Die-cast aluminum body
- Transmission is made of harden alloy steel gears
- All shafts are mounted in ball bearing
- 15-speed control and digital timer
- planetary-mixing action ensures perfect results
- Simple hand lift for tool change and bowl removed

7 Quart MIXER

Optional Accessories:

- 7 Qt. stainless steel bowl
- Dough Hook
- Flat Beater
- Wire Whip

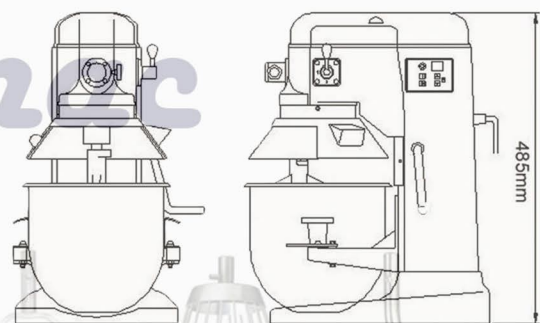
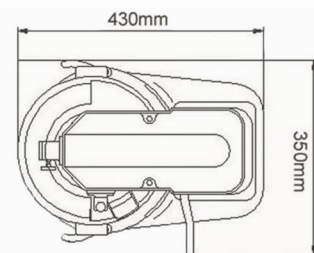

Specifications:

Model No.	Bowl Capacity	Motor	Agitator Speed (RPM)	30 Min. Timer	Safety Guard	N.W.
VM07	7 Quart	650Watts	100-500 RPM	Std.	-	20Kg
VM07(A)	(6.65 Liter)			Std.	Std.	44Lbs.

A - Safety Guard 1 Quart=0.95 liter

* Standard Voltages: 100-120 volts/single phase, 208-240 volts/single phase.

* Due to product improvement, specifications are subject to change without notice.