

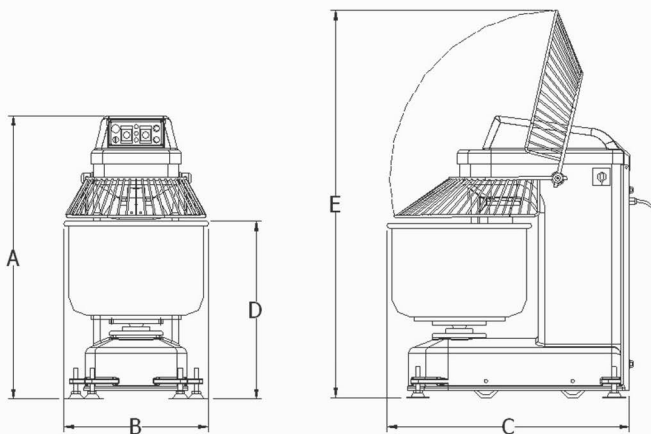

HL-17003K

15L Spiral Mixer



Feature:
The 3kgs flour capacity spiral mixer is with a 2HP motor.

Both the bowl and agitator can rotate and the agitator is with 2-speed option.

Stainless steel safety guard is standard. As the lift of safety guard, the mixer's limit-switch is automatically shut off to protect operator.

Model No.	Capacity		Dimensions(mm)					Net Weight	Motors
	Flour	Bowl	A	B	C	D	E		
HL-17003K	3kg	15L	565	346	586	342	770	55kg	2HP

Note: The water content needs to be above 60%, and the flour below 60% needs to be halved).

The Bakery Equipment Specialist

- * Any three phase is available, please specify voltage when ordering.
- * Due to product improvement, specifications are subject to change without notice.
- * 1 Quart=0.95 Liter