



HL-11012 Series

- *Table Model
- *Three Fixed Speeds
- *Easy Speed-shifting
- *100% Gear Driven
- *Long-life Gearbox
- *Heavy-duty Construction
- *Powerful Motor
- *# 12 Hub

Standard Accessories :

- *Spiral Dough Arm
- *Flat Beater
- *Wire Whip
- *20 Quart Bowl

Optional Accessories :

- *C-type Hook
- *P-Type Beater
- *10 Quart Bowl
- *10 Quart Spiral Dough Arm
- *10 Quart Flat Beater
- *10 Quart Wire Whip
- *Timer
- *Safety Guard
- *Vegetable Slicer Attachment
- *Meat Grinder Attachment
- *Digital Control Panel
- *Scraper



HL-11012AT



HL-11012

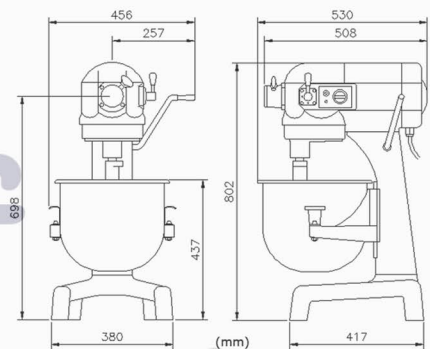

Model No.	Bowl Capacity	Motor	Agitator Speeds(RPM)	Hub	Safety Guard	Timer	Digital Control Panel	N.W.	
HL-11012	20 Quart (19Liter)	1/2HP 0.375 Kw	60HZ:129/240/437 50HZ:140/260/473	Std.	-	-	-	95Kg (209Lbs.) ~98Kg (215Lbs.)	
HL-11012A				Std.	Std.	-	-		
HL-11012T				Std.	-	Std.	-		-
HL-11012AT				Std.	Std.	Std.	-		-

A-Safety Guard T-Timer D-Digital Control Panel 1 Quart=0.95Liter

- * The above specifications do not include all possible combinations of optional accessories.
- * Any voltage is available, please specify voltage and phase when ordering.
- * Due to product improvement, specifications are subject to change without notice