



HL-11007(A) 7QUART MIXER



HL-11007A

- * Professional and counter-top style.
- * Motor offers enough power to mixing stiffer doughs and larger batches.
- * All metal and Die-cast aluminum body.
- * Transmission is made of harden alloy steel gears.
- * All shafts are mounted in ball bearing.
- * Automatic electronic 5-speed control and digital timer.
- * Planetary-mixing action ensures perfect results.
- * Simple hand lift for tool change and bowl removal.
- * Safety guard is standard for model HL-11007A and provides you with automatic shut-off when guard is opened at any speed.

Standard Accessories:

- * 7 Qt. stainless steel bowl
- * Dough hook
- * Flat beater
- * Wire whip



HL-11007

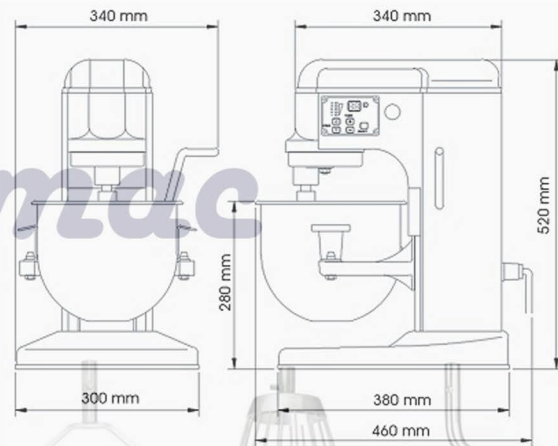

Model No.	Bowl Capacity	Motor	Agitator Speed (RPM)	30Min. Timer	Safety Guard	N.W.
HL-11007	7 Quart	650W(110V)	193-495 RPM	Std.	-	18Kg
HL-11007A	(6.65 Liter)	600W(220V)		Std.	Std.	40Lbs.

A - Safety Guard 1Quart=0.95 Liter

* Standard Voltages: 100-120 volts/single phase, 208-240 volts/single phase.

* Due to product improvement, specifications are subject to change without notice.