



GM12(A) 12QUART MIXER

- * This Mixer is an advance design, highly reliable professional food processing tool.
- * This Mixer is equipped with powerful 1/2 HP motors and strong gear drive design.
- * The gears are made of heat-treated alloy steel and a hardness steel worm wheel.
- * There are 3 speeds and 3 types of accessories, which can be selected to obtain the best result.

Standard Accessories

- * Stainless stell bowl: 1 pc
- * Mixing hook: 1 pc
- * Flat beater: 1 pc
- * Wire whip: 1 pc

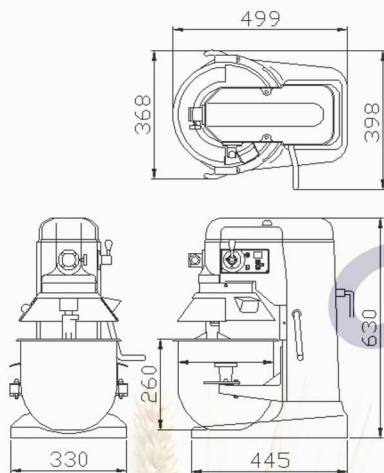

GM12



GM12A

Model No.	Bowl Capacity	Motor	Agitator Speeds(RPM)	Digital Control Panel	30 Min. Timer	Safety Guard	N.W.
GM12	12 Quart	1/2HP	60HZ: 146/262/516	Std.	Std.	-	35Kg
GM12A	(11.4Liter)	0.375 Kw	50HZ: 122/219/430	Std.	Std.	Std.	77Lbs.

H-Hub Attachment A-Safety Guard 1 Quart=0.95Liter

* Available Voltages: 100-120 volts/single phase, 208-240 volts/single phase.

* Due to product improvement, specifications are subject to change without notice.