

# EKF 423 M

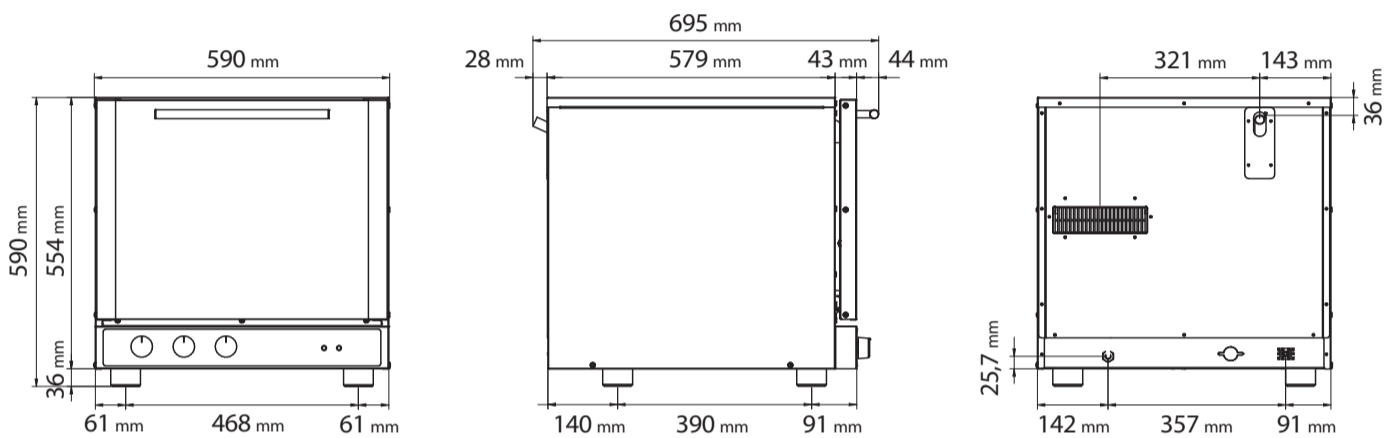

## ELECTRIC CONVECTION OVEN WITH MULTIFUNCTION

Loads of features packed into a compact oven with a pared-back design. Superior cooking performance thanks to a choice of 8 baking options. It caters to the needs of even the most demanding bakeries and pastry businesses, delivering ultimate taste and fragrance each and every time.



DIMENSIONAL FEATURES			
Oven dimensions (WxDxH mm)	590	695	590
Oven weight (kg)	36,4		
Distance between rack rails (mm)	74		

ELECTRICAL FEATURES	
Power supply (kW)	2,6
Frequency (Hz)	50/60
Voltage (Volt)	AC 220/230
N° of motors	1 Unidirectional
Boiler	/
Protection against water	IPX3

EQUIPMENT			
Cardboard box dimensions (WxDxH mm)	650	760	600
Lateral supports	1 right + 1 left		
Aluminum trays (429x345 mm) cod. KV7	4 pcs		
Cable	Single-phase [3G 1,5] - L=1600 mm		

PLUS	
Stainless steel cooking chamber	
Door with inspectionable glass	
Embedded gasket	
Stackable	
Forced cooling system of inner parts	
IPX 3	
New design of cooking chamber	
CB certification	
New design of handle	

FUNCTIONAL FEATURES	
Power	Electricity
Capacity	N° 4 Trays (429x345 mm)
Type of cooking	Multifunction
Humidification	/
Cooking chamber	AISI 430 Stainless steel
Temperature	100 ÷ 260°C
Temperature control	Thermostat
Control panel	Electromechanic – Lower side
N° of programs	/
Programmable cooking steps	/
Pre-heating temperature	/
Pre-heating function	/
Door	Tilt door Ventilated Inspectionable glass
Modularity	Available

OPTIONAL	
Aluminium tray (429x345x9,20 mm)	Cod. KV7
Perforated aluminium tray (435x345x10 mm)	Cod. KTF6P
Horizontal chromed grid (435x340 mm)	Cod. KG7
AISI 304 horizontal grid (435x340 mm)	Cod. KG7X
AISI 430 adapter kit 2/3 GN (354x325 mm)	Cod. KPG23
Kit for overlapping ovens	Cod. EKKM423
Table	Cod. EKT 423 Cod. EKTR 423 Cod. EKTS 423 Cod. EKTRS 423 Cod. EKT 423 D
Proofer	Cod. EKL 823
Optional packaging	Cod. 01300731 Wooden cage (760x840x813 mm) Cod. 01300901 Fumigated pallet ISPM15 (800x1200 x140 mm)