

## POLIN



Head width  
 St/st frame and pivoting wheels with brake  
 Table easy and fast to disassemble  
 Head easy to disassemble and clean  
 St/st rollers head with adaptors for soft doughs  
 Touch screen with TFT display 7"  
 CE conformity declaration  
 It's possible to use different heads to make different products  
 Electronic speed variation of rollers rotation speed  
 Nozzles rotation device  
 Wire cut device  
 Automatic trays advancing with electronic  
 High performing motor for trays advancing  
 Motorised table positioning  
 Automatic and motorised table positioning  
 Back&Forth Drive System  
 Reduced length table with foldable extensions

40-46 optional only with rack	●
●	●
●	●
●	●
●	●
●	●
FR - FL - FXL	●
FET - FL - FXL	●
●	●
FXL	●

### JUNIOR

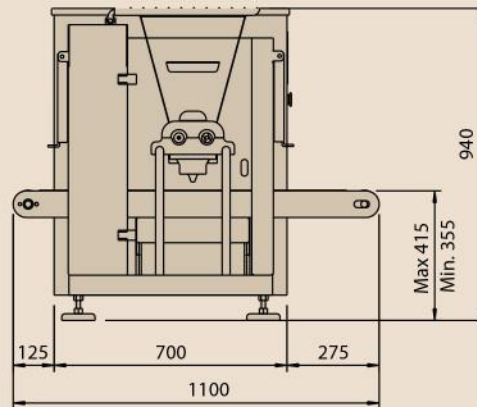
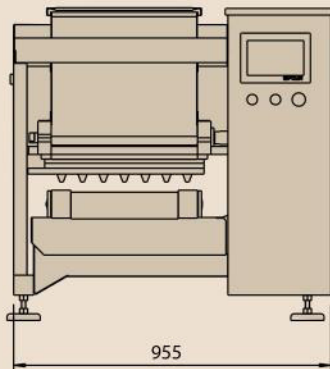

	DIMENSIONE PADELLE TRAYS SIZE DIMENSIONS PLAQUES		DATI TECNICI TECHNICAL FEATURES DONNEES TECHNIQUES					PRESTAZIONI PERFORMANCE PRESTATIONS		DIMENSIONI E PESI DIMENSIONS AND WEIGHT DIMENSIONS ET POIDS	
	Larghezza Width Largeur mm	Lunghezza Length Longueur mm	Tensione Tension Tensions Volt	Potenza Power Puissance kW	Peso Weight Poids Kg	Capacità Capacity Capacité l	Rumorosità Noise level Bruit dB (A)	Colato Dropped Dressé max cicli/1'	Taglio filo Wire cut Coupe à fil max cicli/1'	Imballo Package Emballage mm kg	
<b>FE</b>	400-460	400-700	400/3N~/50	1,1	190	35	<70	20	-	1300 1200 h. 1250	260
<b>FET</b>	400-460	400-700	400/3N~/50	1,1	200	35	<70	20	30	1300 1200 h. 1250	270
<b>FR</b>	400-460	400-700	400/3N~/50	1,3	200	35	<70	20	-	1300 1200 h. 1250	270
<b>FL</b>	400-460	400-700	400/3N~/50	1,3	210	35	<70	20	30	1300 1200 h. 1250	280
<b>FXL</b>	400-460	400-700	400/3N~/50	1,3	220	35	<70	20	30	1300 1200 h. 1250	290