

**Produce high quality, delicious wrapped breads without damaging the dough.**

# COMPACT FN

*STRESS-FREE SYSTEM*

Model Code : FN011

- Stretched dough is set on the upper conveyor of Compact FN before production. The filling is then discharged on to the dough, wrapped and carried out. Compact FN is fully automatic just by placing the dough. Sweet bean paste, curry bread and even more products can be easily molded.
- The filling depositing unit (depositor) can be switched on and off. The system can even wrap hand-deposited filling, and is ideal for small-quantity production. Specifications without a depositor are also available.

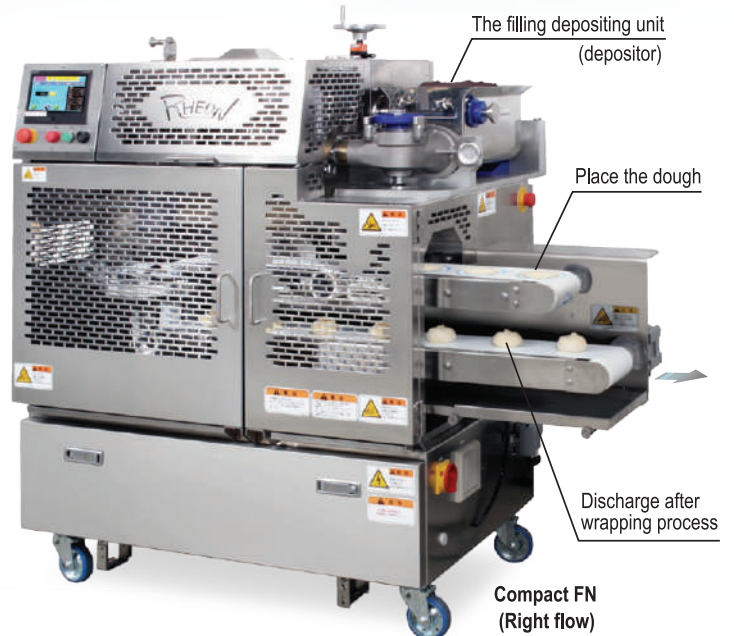

*Anyone can produce these products easily and skillfully.*



Curry Buns



Sweet Bean Paste Buns



Filled Yakisoba Bread



Danish with Crème D'amande

**RHEON**

Since Compact FN is mechanized based on hand-wrapping technology, it can improve production efficiency while maintaining quality.

**Encrusting**  
Forming filled product  
Wrap filling with the encruster.



**Filling depositing**  
Deposits the filling on the dough.



**Auto discharge after dough flattened.**  
Flattened dough is transferred to the Compact FN conveyor.

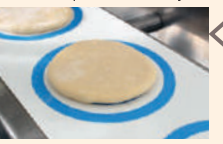

**Place the dough ball**  
Place the dough ball on the Mini Gauge infeed conveyor.



The cylinder is made of stainless steel for great sanitation.

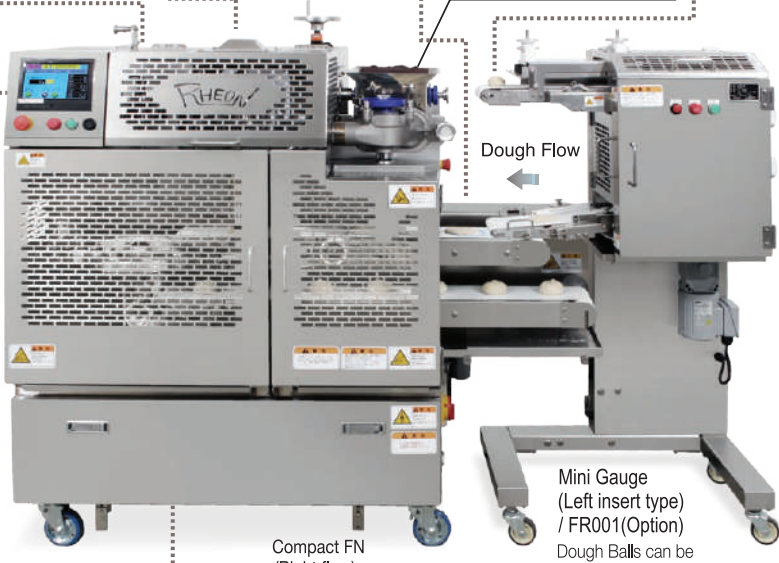

Compact FN (Right flow)

Mini Gauge (Left insert type) / FR001 (Option)  
Dough Balls can be supplied by connecting Mini Gauge.

Equipped with a color touch panel for easy operation.



Illustrations make it easier to understand.

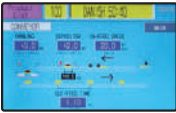

Put your foot under the equipment to alert the sensor to turn on.



Can be used in various ways to expand your product range.

Shut nozzle (optional) can stably deposit even fibrous ingredients.



Filled Kinpira Bread

Open top products can be produced by adjusting wrapping mechanism.



Curry Buns with Open Top

Place the pastry dough cut into a square shape to wrap the cream.

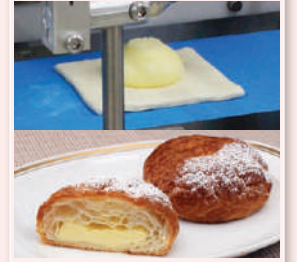

Danish Cream Buns

Place the sweet bean paste and chestnuts on the dough and wrap.



Sweet Bean Paste Bread with Chestnut

Wrap placed chestnuts in pie dough cut into square shape together with filling.



Chestnut Pie

### Dimensions

(Unit: mm)

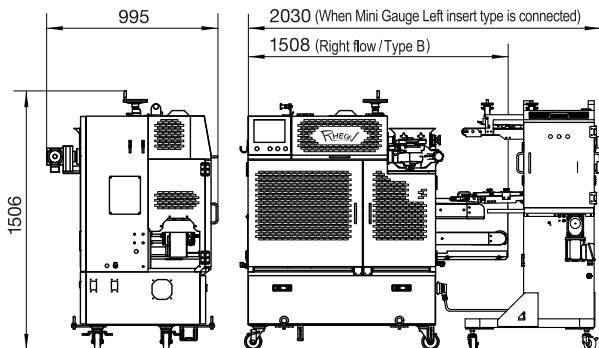

- Compact FN is also available with "Left flow type".
- Mini Gauge is also available with "Right insert type".

### Specifications

| Model Code           | FN011  | FR001                     |
|----------------------|--|---------------------------|
| Length               | 2030 mm (Mini Gauge Left insert type)<br>1508 mm (Right flow / Type B) | 884 mm (Left insert type) |
| Depth                | 995 mm   | 503 mm                    |
| Height               | 1506 mm  | 1447 mm                   |
| Weight               | 500 kg   | 135 kg                    |
| Electric Capacity    | 1.22 kW  | 0.2 kW                    |
| Air                  | 0.4 Mpa, 200 l/min.  | -                         |
| Hopper Capacity      | 15 l   | -                         |
| Encrusting Capacity  | ※20 pcs./min. (MAX)  | -                         |
| Product Weight Range | ※50~200 g  | -                         |

※ Production speed and weight range varies depending on the material. Please make sure by running your own materials.

### Product Example



Cheese Boule



Croquettey Buns



Flied Buns with pickled Nozawana and Mushrooms

The specifications are subject to change without notice and without obligation.  
All Rights Reserved. Reproduction, adaptation or translation without prior written permission is prohibited.

# RHEON

#### RHEON AUTOMATIC MACHINERY CO., LTD.

Head Office: 2-3 Nozawa-machi, Utsunomiya 320-0071, Japan  
Phone: 028-665-1111 E-mail: info@rheon.com URL: https://www.rheon.com

#### RHEON U.S.A.

2 Doppler, Irvine, CA 92618, U.S.A.  
Phone: 949-768-1900 E-mail: us.info@rheon.com URL: http://www.rheonusa.com

#### RHEON U.S.A. NJ BRANCH

700 Huyler Street Teterboro, NJ 07608, U.S.A.  
Phone: 201-487-0600 E-mail: us.east@rheon.com

#### RHEON AUTOMATIC MACHINERY GmbH

Tiefenbroicher Weg 30, 40472 Düsseldorf, Germany  
Phone: 0211-471950 E-mail: de.info@rheon.com URL: https://www.rheon-europe.com

#### RHEON AUTOMATIC MACHINERY GmbH ULM BRANCH

Saumweg 30, 89257 Illertissen, Germany  
Phone: 07303-1599410 E-mail: ulm@rheon.com

#### RHEON AUTOMATIC MACHINERY CO., LTD. TAIWAN BRANCH

5F., No.118, Xinhui 1st Rd., Neihu District, Taipei City, Taiwan (R.O.C.)  
Phone: 02-2792-3525 E-mail: tw.info@rheon.com

#### RHEON AUTOMATIC MACHINERY CO., LTD. SHANGHAI OFFICE

ROOM30, 5F G1FC11, 1438 Hongqiao Road, changning District, Shanghai  
Phone: 86-21-61976378 Fax: 86-21-61976380

© RHEON AUTOMATIC MACHINERY 2020

No. S-FZFN-010-1A  
20032000SK (英語)